

**TABLE OF CONTENTS**

Safety Pre-Cautions.....2

Serial Number and Combination.....2

Lock—Opening Instructions.....2

Moving Your Safe.....3

Placement of Your Safe.....4

Removing the Safe from Pallet.....4

Anchoring Your Safe.....4

Door Adjustments.....5

Loading Your Safe.....5

Cleaning and Maintaining Your Safe.....5

Lost Combination.....6

Troubleshooting Guide.....6

Frequently Asked Questions.....8

Warranty Claims and Repairs.....9

**Congratulations** on your purchase of your new security safe designed by America's #1 gun safe company—Liberty Safe! To insure proper set up and installation, **PLEASE READ THIS USE AND CARE MANUAL** before opening your safe.

### **SAFETY PRE-CAUTIONS**

The safe door is heavy. Do not open the door with the safe on an uneven or unstable floor. Hanging on an open door may cause the safe to tip forward when not lag-bolted to the floor, resulting in serious injury or death to yourself or others. If you have or have occasion to have small children in your home, please make sure you never leave your safe unsecured. It is possible for small children to climb inside your safe and become locked in. This could result in serious injury or death.

### **INSPECT YOUR SAFE**

Inspect your safe for shipping damage as soon as you receive it. If you find any damage, please contact the delivery company (or carrier) immediately. Any damage not noted upon delivery must be reported within fifteen (15) days or there will be no recourse.

### **PACKAGING MATERIALS**

After opening the safe, please remove the door's corner protectors. The fire seal is also covered with a black protective shipping tape. Please remove tape before using the safe.

### **SERIAL NUMBER & COMBINATION** (See opening instructions before proceeding)

Your safe's **serial number** is located in two (2) locations on the safe. One is located on the top of the safe, back right side (may also be on the back of the safe, top right side). The second is located just inside the door by the bolts. Compare the serial number in this manual with the serial number on the safe. All serial numbers should match. If they do not, contact your local dealer or Liberty Safe immediately. **You will need your safe serial number when contacting customer service about your safe.**

 **PLEASE NOTE:** Record your safe's serial number and combination and store in a secure location ***OTHER THAN YOUR SAFE***.

### **LOCK—OPENING INSTRUCTIONS**

The combination lock on your safe has been set randomly at the factory. After completely dialing the combination provided with your safe, turn the safe handle and open door. With the door open it is recommended that you verify the combination opens a few times before using the safe. It is also strongly recommended to do this after moving the safe.

## **EXTENDING BOLTS BEFORE VERIFYING COMBINATION**

It is preferred to verify your safe combination **with the door open**. If there are problems, it is easier to service the lock or mechanism with the door open. Before verifying your combination, you will need to extend the door bolts while the door is open. Keep door open.

## **VERIFYING THE COMBINATION**

With the bolts extended and door open, you can now verify your combination. The lock requires accurate alignment with the index mark (located at twelve noon on the dial ring). Always turn the dial slowly and steadily when entering your combination to avoid dialing past your numbers. **Never spin the dial rapidly back and forth as this may cause damage to the lock.** If you go past any number - even if by only a half a number - the entire combination must be re-dialed. To verify your combination, follow the four steps below. Copy your combination numbers from page 2 to the spaces below.

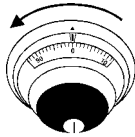

### **Step 1**

Turn the dial counterclockwise (LEFT) passing the 1<sup>st</sup> number twice and stopping on it the 3<sup>rd</sup> time.

1<sup>st</sup> # \_\_\_\_\_

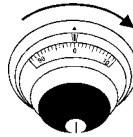

### **Step 2**

Turn the dial clockwise (RIGHT) passing the 2<sup>nd</sup> once and stopping on it the 2<sup>nd</sup> time.

2<sup>nd</sup> # \_\_\_\_\_

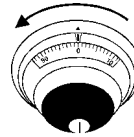

### **Step 3**

Turn the dial counterclockwise (LEFT) and stop on the 3<sup>rd</sup> number.

3<sup>rd</sup> # \_\_\_\_\_

**Step 4** – If combination is entered correctly, you will be able to turn the safe handle.

**⚠ IF COMBINATION DOES NOT WORK, DO NOT CLOSE THE DOOR! Try Again.** Refer to the TROUBLE SHOOTING GUIDE in the back of this manual for more help.

## **MOVING YOUR SAFE**

### **⚠ SAFETY PRE-CAUTIONS**

Before moving the safe, make sure you have completely tested the combination and lock to assure it will open properly prior to removing the safe from the pallet and to its final location. Safe doors are NOT designed to be removed due to possible serious injury. Never move the safe with the door open. Do not open the door with safe lying down. The safe's door should never be removed. Safes are very heavy and awkward to handle. Only use of proper moving equipment by a trained professional is recommended. Using a standard refrigerator dolly is very dangerous and can cause injury or death.

### **PLACEMENT OF YOUR SAFE**

Before moving your safe, verify the load bearing weight of the floors and stairs, and types of flooring the safe will be moved over (tile, wood, and other flooring can be damaged by the weight of the safe). To determine whether or not your safe will make it through doorways, stairs or corners take the empty safe box and see if it will fit all the way through to its final location.

**i** Proper installation and anchoring are critical to the security of your safe. Make sure you consider the following:

- Install near a load-bearing wall as a precaution to supporting the weight of the safe.
- To help protect the exterior finish of your safe, install inside your home in a dry location where there is climate control (heat in the winter and cooling in the summer).
- The safes fire rating depends upon the number of layers of fireboard and BTU rating. Generally speaking, fire safes perform better in lower levels of a home (like the basement) where fire temperatures are lower. Additionally, placement of your safe away from potential hot spots (areas where flammable materials are stored) will improve your chances that your safe and its contents will perform better in a home fire. No safe is completely fireproof. If the fire reaches a high enough temperature for long periods, fire damage may occur.
- To store photographs, negatives, CD's or other electronic media, a Media Cooler Storage unit inside your safe is recommended for heat sensitive items.

### **REMOVING THE SAFE FROM PALLET**

With the safe upright and open, lift the floor fabric or access panels on both sides of the floor. Pry up the black caps to expose the mounting bolts. Have someone steady the safe while removing the safe from the pallet to prevent the safe from tipping forward. Use a 5/8" ratchet to remove the bolts. Close and lock the door to prevent accidental opening while removing the safe from the pallet to the final location. Make sure you have adequate help to tilt the safe from its side until the edge of the safe is resting on the floor. While tilted, remove the pallet out from under the safe. Carefully lower the safe back to its upright position.

### **ANCHORING YOUR SAFE**

**To achieve the highest level of security it is REQUIRED that you anchor your safe securely to the floor.** We recommend placing a protective barrier (such as a piece of carpet, treated wood or rubber mat) between the safe and floor to prevent scratching of the safe surface, which could lead to rust. Before anchoring safe, make sure the safe is level. Use redwood door shims to adjust safe level so the door has the desired swing. Use appropriate hardware for the wood or cement surface you are anchoring to. Anchoring kits with instructions are available from your dealer. Given enough time it is possible for a thief to break into a safe. Securing it to the floor helps secure and prevent removal of the safe by thieves.

### DOOR ADJUSTORS

Most safe models have one or two door adjustors for tightening or loosening the door. These adjustors are located just inside the left side of the safes doorjamb. After removing the shipping protectors, close the door and extend the bolts. Pull out on the door handle to feel the tightness. If there is play in

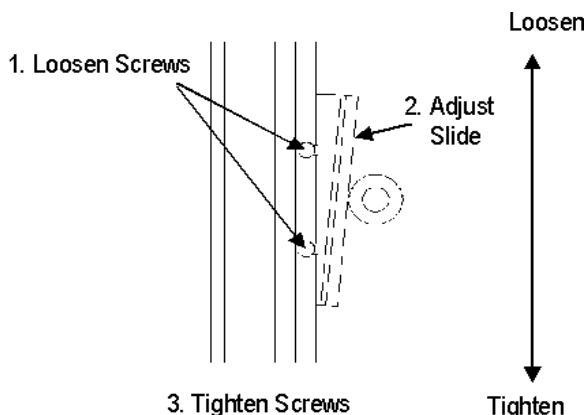

the door, you will need to adjust the slide. Using the supplied hex wrench, loosen the two (2) door adjuster mounting screws. Slide the adjuster up to loosen the door, down to tighten the door. Re-tighten screws and check door again for fit. When properly adjusted, you should feel slight resistance when extending the door bolts. Only slight movement should be felt with the door shut. **Caution: Do not adjust door too tight. This may cause wear on both the door pins and locking mechanism. If your door has a tendency to self-open (the bolts retract by themselves), the door adjustors may be too tight.**

## USING & MAINTAINING YOUR SAFE

### LOADING YOUR SAFE

- When putting guns into your safe, make sure they rest securely against the cutouts provided to prevent accidental tipping when the door is closed.
- Store documents and ammunition in the bottom of the safe for greatest protection against fire damage.
- If you are storing electronic media, use a Media Cooler to provide additional protection (See your local dealer or visit [www.libertysafe.com](http://www.libertysafe.com)).
- Do not put anything in your safe that will put pressure against the door, or the chrome locking bolts when the door is closed.
- If you live in a humid environment, it is recommended that you use a **dehumidifier** or **desiccant** to protect the contents from rust or mildew. Dehumidifiers and other moisture reducing products suitable for your safe are available from your dealer. Do not install or store these devices or any other personal contents near the chrome locking bolts on the door as this could interfere with the function of the mechanism in the door.

### CLEANING AND MAINTAINING YOUR SAFE

- **Manual Locks** – It is recommended that you have your manual lock serviced annually by a certified lock technician to maintain trouble-free service.

- **Chrome Locking Pins** – Once per year extend the bolts and wipe a small amount of grease along the bottom and front side of the pin.
- **Internal Locking Mechanism** – The advanced locking mechanism requires no maintenance. Opening the door panel of your safe by anyone other than a certified lock or safe technician may void your warranty.
- **Exterior** – Use a soft, non-abrasive cloth dampened with water to clean the surface of a gloss, powder coat or textured finish safe. Other materials may cloud or scratch the finish of your safe:
  - Logos and other graphic images must be wiped gently. Never rub or polish
  - The lock and handle have a protective coating to prevent tarnish. **DO NOT** use metal polishes or solvents for cleaning. Simply wipe off with a soft cloth.
  - Scratches and other blemishes may be touched up with a paint touch up kit available from your dealer.
- **Fire Seal** – The fire seal does not need maintenance unless it is ripped or destroyed. If the seal becomes damaged, call for replacement pieces. The Palusol® fire seal used provides additional fire protection. Once the temperature reaches 212° it expands up to seven (7) times it's flat size and fills the joints and gaps resisting penetration of smoke and heat.

### **LOST COMBINATION**

The lock on your safe has been set with a randomly selected combination at the time of manufacturing. As part of our continuing service, a record of your combination by serial number is kept on file. If you lose your combination, you can retrieve a copy for a \$15.00 research fee, **provided you have not changed the lock on your safe**. You must complete certain security and documentation requirements. Call a CSR at (800) 247-5625, press 0, or go to [www.libertysafe.com](http://www.libertysafe.com) to download a combination request form.

## **TROUBLE SHOOTING GUIDE**

### **Problem**

### **Possible Solution**

#### **Combination Will Not Open the Safe**

Check lock-bolt pressure. Some free play should exist in the handle, left to right. Redial the complete combination stopping on the third number. Hold dial while shaking the handle back and forth. **PLEASE NOTE:** If your lock still does not open, it is possible that one or more of your numbers may be off slightly from those shown in this manual. The combination number may have shifted slightly during shipping. Try dialing 1 up or 1 down from each number in the combination. If it opens with a new number, update your combination in this book and report it to Liberty Safe (800) 247-5625, Press 0.

<b>Combination Opens the Safe Intermittently</b>	Check lock-bolt pressure. Some free play should exist in the handle, left to right. Try dialing the combination again. Bolt pressure may be due to out of place interior shelves or improper personal storage (i.e. gun barrels, items too big for shelves).
<b>Combination Dial Is Tight or Will Not Turn</b>	Check lock-bolt pressure. Some free play should exist in the handle, left to right. Bolt pressure may be due to out of place interior shelves or improper personal storage. Make sure the locking bolts are in the fully extended position with the door completely closed or completely open. Normally dial tightness varies from safe to safe. Tightness of dial may increase or decrease as dial is being turned.
<b>Combination Works But Handle Will Not Turn</b>	Corner protectors (packaging material) may cause undue pressure on the locking bolts. To alleviate the pressure push in on the door while pulling out and turning the handle to open the safe. If the handle turns partially the bolts may be jammed or caught up. Try rotating the handle back and forth (left to right) until the bolts free up. Use a cotton cloth and light oil to rub each bolt entirely, front and back of door.
<b>Combination Works and Handle Turns But Safe Will Not Open</b>	Verify that the handle has been completely rotated before opening the door. Check the <b>5/16" Allen set screw</b> located on either the side or front of the handle hub (center of handle) for tightness. Some safes are installed with a unique handle clutch mechanism. Improper personal storage or excess door adjustment may cause clutch to temporarily engage. Push in on the door while turning and pulling out on the handle to open.
<b>Door Rattles When Shut</b>	Verify that the handle is rotating completely and that the locking bolts are fully extending. Refer to the Door Adjustment Procedures on page 5.
<b>Door Will Not Shut</b>	Verify that the lock is unlocked and the locking bolts are fully retracted. Make sure the interior shelves are pushed back as far as possible. The handle should travel the same distance with the door closed as it does with the door open all of the way. (When the door is open all of the way it will form a 90-degree angle to the body of the safe.)
<b>Door Shuts But Will Not Lock</b>	Verify that the door is shut completely, the handle rotated completely and locking bolts extended to their locked position. Then rotate the dial to lock the safe. Verify that interior shelves are pushed back as far as possible

**Chrome Locking Bolts** Bolts may become dry and need oil. Use a cotton cloth and light oil to rub each bolt entirely, front & back of door.  
**Do Not Retract to Close Door**

### FREQUENTLY ASKED QUESTIONS

Q. Can I change the safe's combination?

A. The combination on this lock cannot be changed.

Q. Why is the handle pointing in a different direction than it used to be?

A. The handle has a built in clutch mechanism. When the handle is forced it will slip left, or right. To reset it simply force it back to it's original position when locked.

Q. What is routine maintenance and who is qualified to do it?

A. Routine maintenance is to keep your safes lock in good working condition and may prevent costly lockouts. Most locksmiths can perform the work.

Q. What if I lose my combination?

A. A Combination request form must be filled out and faxed along with a copy of the sales receipt to: **(801) 465-2712**. You can print a form from our website [www.libertysafe.com](http://www.libertysafe.com) under the Owner Services tab or have one faxed or mailed by calling our toll free customer service line at (800) 247-5625, press 4.

### WARRANTY CLAIMS

Please read carefully the safe warranty that accompanied your safe. If you encounter a problem that falls under the warranty coverage, simply call one of our CSR's at (800) 247-5625, press 0. You will be required to provide the serial number and proof of ownership if you have not sent in your warranty card.

### WARRANTY REPAIRS

Repairs to your safe covered under your warranty should not be performed without the pre-authorization of a Liberty customer service representative. If there are any issues regarding your safe please contact a Liberty Safe Customer Service Representative (CSR) at (800) 247-5625. Solutions to frequently asked questions and issues can also be found in Trouble Shooting Guide in this booklet or on line at [www.libertysafe.com](http://www.libertysafe.com). The cost of any repairs performed without pre-authorization will be the sole responsibility of the owner.

### WATER AND FIRE DAMAGE

Your safe is not waterproof. Should your safe be exposed to fire or water, the fire insulation of your safe will be compromised. In this event, make sure to have your safe opened as soon as possible. If your safe included firearms, remove them and have them cleaned and lubricated as soon as possible. Do not continue to store items in a safe that has been compromised by water or fire. You should purchase a replacement model in either case.

**INSURANCE COVERAGE**

Liberty safe does not insure the contents of your safe. A homeowner's policy or other insurance coverage should be purchased in an amount sufficient to cover the contents. Most homeowner's policies require the purchase of riders or endorsements on items such as guns, jewelry coins and other valuable collectibles. Should damage occur to your valuables, a claim should be made with your homeowners insurance. Check with your local insurance company for possible discounts that may be available with your purchase.

---

Notes